

Replacement Instructions for Limit Switch Assembly 41D4671

You will need a 1/4" magnetic nut driver.

1. Fully close the garage door.
2. Disconnect power to the opener.
3. Remove the opener lens (refer to your owner's manual).
4. Remove the cover:
 - Using a 1/4" magnetic nut driver, remove the two screws recessed in the bottom of the cover.
 - Unplug the wires to the light sockets inside, and place the cover aside.
5. Lift off the control center access door and set aside.
6. Unfasten the receiver logic board assembly from the chassis by removing the two screws inside the panel under the top edges **(a)**. Allow it to hang suspended by wires.
7. Disengage the limit switch assembly **(b)** from the retention slots in the limit switch bracket **(c)** by squeezing the top and bottom on the right near the drive gear (see illustration).
8. Disengage the hook on the left **(d)** and allow assembly to hang by wires.
9. Position the new limit switch in front of you as shown in Figure 2. The drive gear controls the movement of the center limit contact to the left (UP) or right (DOWN). Rotate the gear until the center limit contact touches the DOWN contact.
10. Remove the wires one at a time from the original limit switch and reconnect them to the new assembly.
11. Reverse steps 3-8 to install the new assembly and reassemble the unit.
12. Restore power to the opener. Readjustment of the UP and DOWN travel limits may be necessary. Refer to your owner's manual.

NOTE: A TEST OF THE SAFETY REVERSE SYSTEM IS NECESSARY FOR SAFE OPERATION. Follow the instructions on side two or in your owners manual.

CAUTION

The garage door **MUST** be in the fully closed position during installation.

WARNING

To prevent possible **SERIOUS INJURY** or **DEATH** from electrocution, disconnect power to opener **BEFORE** proceeding.

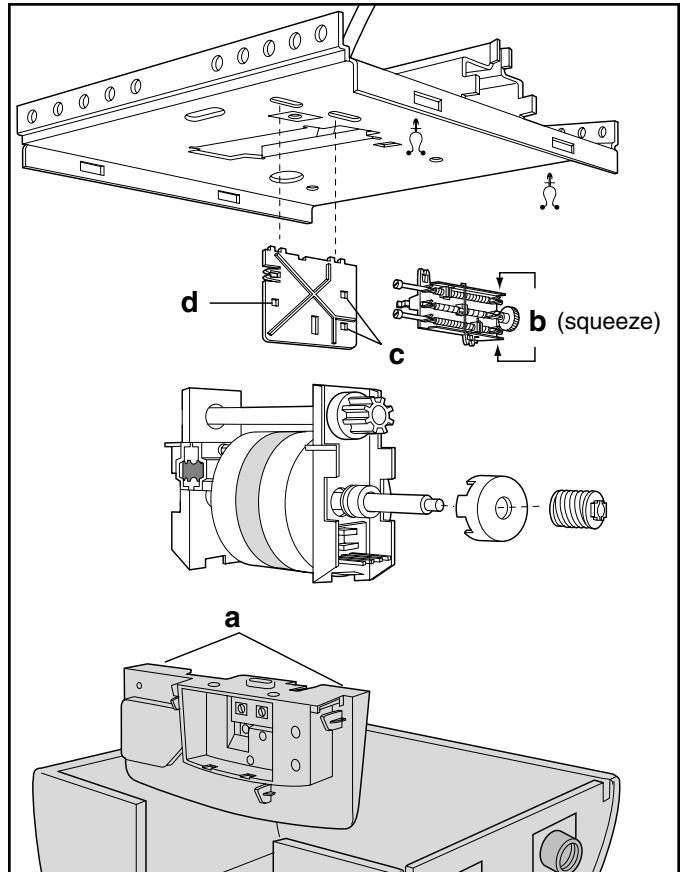

Figure 1

LIMIT SWITCH ASSEMBLY

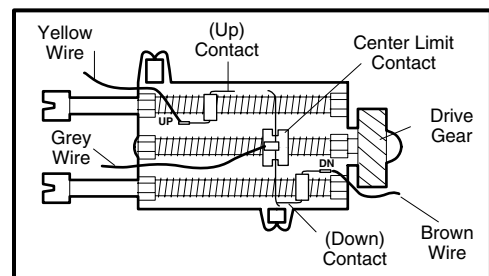

Figure 2

Testing the Safety Reverse System:

TEST:

- With the door fully open, place a 1-1/2" (3.8 cm) board (or a 2x4 laid flat) on the floor, centered under the garage door.
- Operate the door in the down direction. The door **must** reverse on striking the obstruction.

ADJUST:

- If the door stops on the obstruction, it is not traveling far enough in the down direction. Increase the DOWN limit by turning the DOWN limit adjustment screw counterclockwise 1/4 turn.

NOTE: On a sectional door, make sure limit adjustments do not force the door arm beyond a straight up and down position.

- Repeat the test.
- When the door reverses on the 1-1/2" (3.8 cm) board, remove the obstruction and run the opener through 3 or 4 complete travel cycles to test adjustment.
- If the unit continues to fail the Safety Reverse Test, call for a trained door systems technician.

IMPORTANT SAFETY CHECK:

Test the Safety Reverse System after:

- Each adjustment of door arm length, limits, or force controls.
- Any repair to or adjustment of the garage door (including springs and hardware).
- Any repair to or buckling of the garage floor.
- Any repair to or adjustment of the opener.

WARNING

Without a properly installed safety reversal system, persons (particularly small children) could be SERIOUSLY INJURED or KILLED by a closing garage door.

- Safety reversal system **MUST** be tested every month.
- If one control (force or travel limits) is adjusted, the other control may also need adjustment.
- After ANY adjustments are made, the safety reversal system **MUST** be tested. Door **MUST** reverse on contact with 1-1/2" high (3.8 cm) object (or 2x4 laid flat) on the floor.

