

DD08900W LIGHT-DUTY COMMERCIAL JACKSHAFT DOCK DOOR OPERATOR FOR SECTIONAL DOORS



SECTION 08 71 13

KEY FEATURES

STANDARD APPLICATION	Ideal for applications using smaller, lighter commercial sectional doors on high-lift and full vertical lift with light-duty cycle requirements
RATED DUTY CYCLE	Light-duty: Up to 10 cycles/hour; fewer than 25 cycles per day
OPERATOR SPEED	12-15 Inches per second in up direction; 7.5-8.5 inches per second in down direction
LIMIT SETTINGS	Electronic
EMERGENCY DISCONNECT FOR MANUAL OPERATION	Emergency release sash chain
EMERGENCY DISCONNECT WITH AUTO-RECONNECT	To reconnect, pull down on the sash chain again to re-engage
PROGRAMMING	Tactile buttons
CIRCUIT BOARD	Solid-state circuit board
MOTOR OPERATOR WALL CONTROL	3-button control station
COMMERCIAL INPUTS	Flasher circuit and interlock
CONNECTIVITY INTERFACE	LMI5 Interface Device monitors up to 5 external sensors (myQ® Business™ Facility subscription required for visibility to this data)

SPECIFICATIONS

RADIO RECEIVER	LiftMaster® Security+ 2.0®
VOLTAGE CONNECTIONS	120VAC
DRIVE REDUCTION	Heavy-duty 12VDC
WARRANTY	2 years

INSTALLATION FEATURES

UNIVERSAL MOUNTING	Yes, can be mounted to either the right or left side of the door without the need for any special accommodations
MAXIMUM DOOR HEIGHT	14 feet
MAXIMUM DOOR WIDTH	18 feet
MAXIMUM ALLOWABLE SQUARE FOOTAGE	180 square feet
MAXIMUM DOOR WEIGHT	300 lbs.
INTERNET CONNECTIVITY	myQ® Technology enables remote monitoring and control of the commercial door via a smartphone, tablet, or computer***

This commercial door operator must feature constant pressure to close or be equipped with an external monitored entrapment protection device. Use only LiftMaster monitored entrapment protection devices itemized on the accessory page of the operators installation manual to meet UL 325 requirements.

***Operator directly connects via built-in wi-fi, subscription to myQ Business™ Facility required.

DATA SHEET
JACKSHAFT DOCK DOOR OPERATOR
FOR SECTIONAL DOORS

LiftMaster®

DD08900W LIGHT-DUTY COMMERCIAL JACKSHAFT DOCK DOOR OPERATOR FOR SECTIONAL DOORS

SECTION 08 71 13



DIMENSIONS

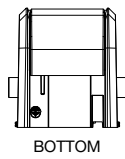
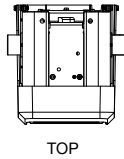
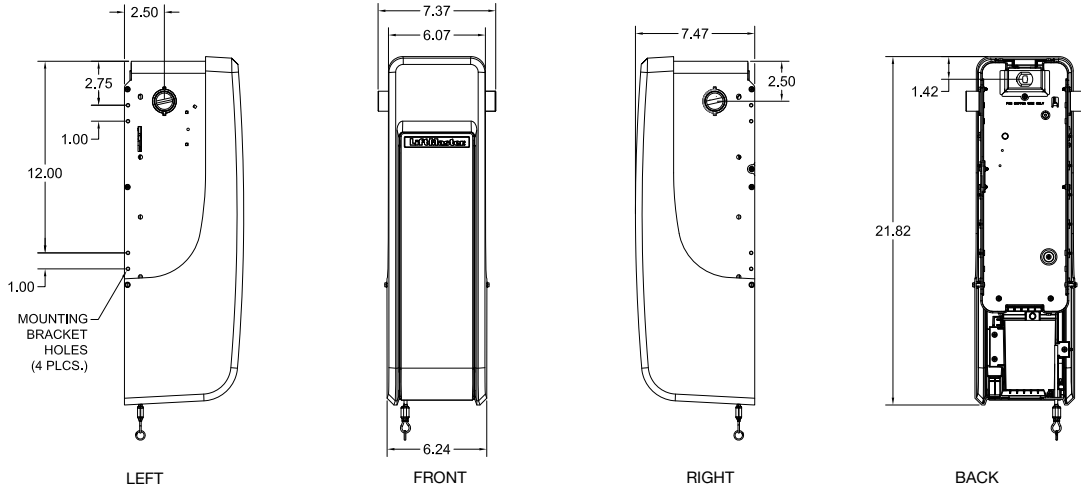

LM15 INTERFACE DEVICE

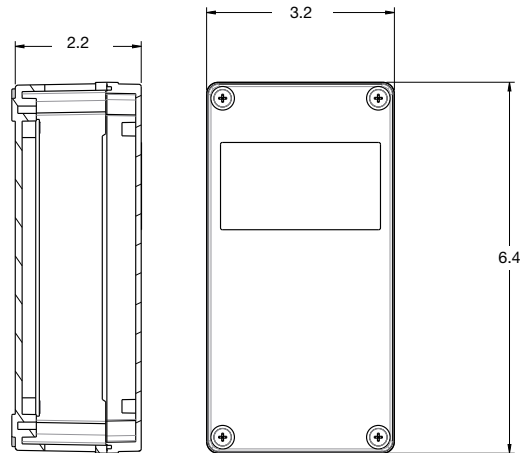

CAPACITY

MAXIMUM DOOR AREA (SQ. FT.)			
	MAX. HEIGHT	MAX. WIDTH	MAX. SQ FT.
SECTIONAL	14 FT. OR	16 FT.	180 FT. TOTAL
	HEADROOM CLEARANCE REQUIRED: 3 IN. FROM CENTER OF TORSION BAR MAX. DOOR WEIGHT: 300 LBS.		

Recommended duty cycle: 10 cycles per hour; fewer than 25 cycles/day.